

202000299929
Filed for Record in
OTTAWA COUNTY, OHIO
VIRGINIA M PARK, RECORDER
10-22-2020 At 02:51 pm.
AFFIDAVIT 50.00
OR Book 1801 Page 310 - 313

AFFIDAVIT

STATE OF OHIO

OTTAWA COUNTY

DRAINAGE IMPROVEMENT: Rockport Subdivision

The undersigned, Ronald P. Lajti, Jr., P.E., P.S., after being duly cautioned and sworn, deposes and states as follows:

1. That his name is Ronald P. Lajti, Jr.; that he is of the age of majority; that his business address is 8247 West State Route #163, Oak Harbor, Ohio 43449, and that he is the County Engineer for Ottawa County, Ohio.
2. This affidavit is being filed with a plat of Rockport Subdivision Drainage Improvement Project.
3. This project has a closed ditch.
4. The attached list contains information on parcels of land that have been identified as benefiting from this drainage improvement project. This list contains the following information:
 - a. Name of the land owner
 - b. Parcel number
 - c. Brief legal description of the parcel
 - d. Subject to an easement (for parcels adjacent to the improvement)
5. All parcels are subject to maintenance assessments. Collected funds will be used for the upkeep of the drainage improvement as prescribed in Ottawa County Commissioners Resolution 19-37 and Ohio Revised Code Section 6137.

6. As per Ohio Revised Code Section 6137.12, parcels adjacent to the improvement are subject to a permanent easement for the maintenance and cleaning of the ditch.
- a. This easement shall not exceed eighty (80) feet centered on the centerline of the improvement.
 - b. The easement extends along the entire length of a property adjacent to the improvement and is further identified in the attached plat.

The Affiant says nothing further.



Ronald P. Lajti, Jr., P.E., P.S.
Ottawa County Engineer

Sworn to and subscribed before me, a Notary Public in and for the State of Ohio, by Ronald P. Lajti, Jr., P.E., P.S., on the 21st day of October, 2020, witness my official seal and signature.



(Signature)

TINA MOLNAR

My Commission Expires:

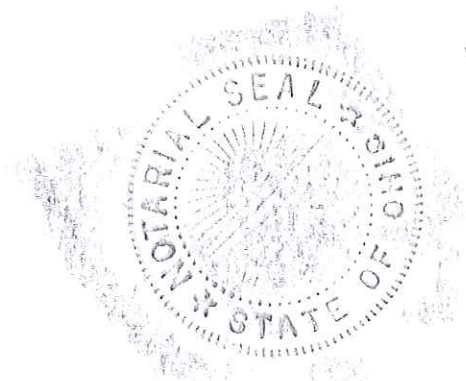
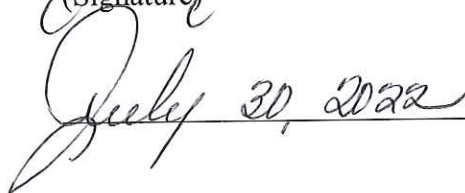

OWNER LIST - ROCKPORT DRAINAGE PETITION NO. 111				
PLAT REF. NO.	OWNER	PARCEL NO.	LEGAL DESCRIPTION	EASEMENT
1	TIMOTHY & JENNIFER HEFERNAN	0141674330850010	LOT 9 ROCKPORT SUBD.	X
2	KEITH & KATHLEEN JOY	0141674330850011	LOT 10 ROCKPORT SUBD.	X
3	ROBERT & BETH HAYNER	0141674330850012	LOT 11 ROCKPORT SUBD.	X
4	RICHARD & ROSEMARY MAZUREK	0141674330850013	LOT 12 ROCKPORT SUBD.	X
5	DAVID & ANN ZIELINSKI	0141674330850014	LOT 13 ROCKPORT SUBD.	X
6	PHYLLIS & WARREN CERMAK	0141674330850015	LOT 14 ROCKPORT SUBD.	X
12	PJWK LAND COMPANY LIMITED	0142099134670000	PART SECTION 1, LOTS 2 & 4, DANBURY TWP.	
13				
14				
18	MARK & KATHLEEN LUCAS	0142099134670036	LOT 36 LIGHTHOUSE BLUFFS AMENDED 3/8/99	
19	JOHN IRVINE	0142099134670035	LOT 35 LIGHTHOUSE BLUFFS AMENDED 3/8/99	
20	SCOTT A & CAROL MIESLE	0142099134670034	LOT 34 LIGHTHOUSE BLUFFS AMENDED 3/8/99	
21	RICHARD & MARILYN MINTO	0142099134670033	LOT 33 LIGHTHOUSE BLUFFS AMENDED 3/8/99	
22	JEANNE Z WALKER	0142099134670032	LOT 32 LIGHTHOUSE BLUFFS AMENDED 3/8/99	
23	MARC C & VICKI MCCLAIN	0142099134670031	LOT 31 LIGHTHOUSE BLUFFS AMENDED 3/8/99	
24	LANNY & FAITH MOLDOVAN	0142099134670030	LOT 30 LIGHTHOUSE BLUFFS AMENDED 3/8/99	
25	WILLIAM BRANTSCH	0142099134670029	LOT 29 LIGHTHOUSE BLUFFS AMENDED 3/8/99	
26	MICHAEL & ROSEMARY DZIAK	0142099134670028	LOT 28 LIGHTHOUSE BLUFFS AMENDED 3/8/99	
27	ALAN STEFFEN	0142099134670027	LOT 27 LIGHTHOUSE BLUFFS AMENDED 3/8/99	
28	BRANDI MCBRIDE	0142099134670026	LOT 26 LIGHTHOUSE BLUFFS AMENDED 3/8/99	
29	JAMES WAGNITZ	0142099134670025	LOT 25 LIGHTHOUSE BLUFFS AMENDED 3/8/99	
30	JAMES & CYNTHIA FISH	0142099134670024	LOT 24 LIGHTHOUSE BLUFFS AMENDED 3/8/99	
31	LINDA SMITH	0142099134670023	LOT 23 LIGHTHOUSE BLUFFS AMENDED 3/8/99	
32	UFHOLZ L TERRENCE SUCCESSOR TR	0142099134670022	LOT 22 LIGHTHOUSE BLUFFS AMENDED 3/8/99	
33	UFHOLZ L TERRENCE SUCCESSOR TR	0142099134670021	LOT 21 LIGHTHOUSE BLUFFS AMENDED 3/8/99	
34	JOHN CRAWLEY	0142099134670020	LOT 20 LIGHTHOUSE BLUFFS AMENDED 3/8/99	
35	RUKMAN SUTANTO	0142099134670019	LOT 19 LIGHTHOUSE BLUFFS AMENDED 3/8/99	
36	ELMER & ANN BIVEN	0142099134670018	LOT 18 LIGHTHOUSE BLUFFS AMENDED 3/8/99	
37	PATRICIA AHRENS	0142099134670017	LOT 17 LIGHTHOUSE BLUFFS AMENDED 3/8/99	
39	GIBBONS CATHLEEN A	0142099134670075	LOT 74 LIGHTHOUSE BLUFFS SUBD., PHASE II	
40	GRIFFIN DEBRA D	0142099134670074	LOT 73 LIGHTHOUSE BLUFFS SUBD., PHASE II	
41	ARMADILLO REAL ESTATE HOLDINGS LLC	0142099134670073	LOT 72 LIGHTHOUSE BLUFFS SUBD., PHASE II	
42	ARMADILLO REAL ESTATE HOLDINGS LLC	0142099134670072	LOT 71 LIGHTHOUSE BLUFFS SUBD., PHASE II	
43	CLEMONS CHRISTOPHER M & DEBRA S S&T	0142099134670071	LOT 70 LIGHTHOUSE BLUFFS SUBD., PHASE II	
44	WISE EMILIA	0142099134670070	LOT 69 LIGHTHOUSE BLUFFS SUBD., PHASE II	
45	BURMEISTER RANDY A & JUDY A S&T	0142099134670069	LOT 68 LIGHTHOUSE BLUFFS SUBD., PHASE II	
46	FLOWERS GARY S & CYNTHIA J S&T	0142099134670068	LOT 67 LIGHTHOUSE BLUFFS SUBD., PHASE II	
47	VAN CLEVE MICHAEL R & CYNTHIA R S&T	0142099134670067	LOT 66 LIGHTHOUSE BLUFFS SUBD., PHASE II	
48	FULKERSON KATHRYN A	0142099134670066	LOT 65 LIGHTHOUSE BLUFFS SUBD., PHASE II	
49	DAVIS TAMMY L TRUSTEE	0142099134670065	LOT 64 LIGHTHOUSE BLUFFS SUBD., PHASE II	
50	CAMPBELL STEVEN V & WANDA K S&T	0142099134670064	LOT 63 LIGHTHOUSE BLUFFS SUBD., PHASE II	
51	ROTHENBUHLER MARVIN C TOD	0142099134670063	LOT 62 LIGHTHOUSE BLUFFS SUBD., PHASE II	
52	MCCARTHY PATRICK M & WENDY E S&T	0142099134670062	LOT 61 LIGHTHOUSE BLUFFS SUBD., PHASE II	
53	ZLOKAS ROBERT S & FRANCES A S&T	0142099134670061	LOT 57A LIGHTHOUSE BLUFFS SUBD., PHASE II	
55	GAST CAROLYN A	0142099134670059	LOT 56A LIGHTHOUSE BLUFFS SUBD., PHASE II	
56	TUTTAMORE WILLIAM M TRUSTEES	0142099134670057	LOT 55A LIGHTHOUSE BLUFFS SUBD., PHASE II	
57	BOARD OF EDU OF DANBURY LOCAL SCHOOLS	0140214229792000	PART SECTION 1, LOTS 2 & 4, DANBURY TWP.	
58	VETOVITZ WILLIAM H & JOHANNA L S&T	0142099134670054	LOT 53A LIGHTHOUSE BLUFFS SUBD., PHASE II	
59	CLEMONS DONALD J & PATRICIA A	0142099134670055	LOT 54A LIGHTHOUSE BLUFFS SUBD., PHASE II	

OWNER LIST - ROCKPORT DRAINAGE PETITION NO. 111				
PLAT REF. NO.	OWNER	PARCEL NO.	LEGAL DESCRIPTION	EASEMENT
60	WINDRIDGE HOMES LIMITED	0142099134670050	LOT 49A LIGHTHOUSE BLUFFS SUBD., PHASE II, REPLAT 65	
62	SHROCK BRYAN A & MARIA S&T	0142099134670049	LOT 48 LIGHTHOUSE BLUFFS SUBD., PHASE II	
63	MINNEMAN JOHN E & TERRIE A S&T	0142099134670048	LOT 47 LIGHTHOUSE BLUFFS SUBD., PHASE II	
64	PIERCE ROLAND & SHIRLEY A CO TRUSTEES	0142099134670047	LOT 46 LIGHTHOUSE BLUFFS SUBD., PHASE II	
65	BENYA JOHN M & BRIAN R	0142099134670046	LOT 45 LIGHTHOUSE BLUFFS SUBD., PHASE II	
66	MURNIEKS JUNE R	0142099134670045	LOT 44 LIGHTHOUSE BLUFFS SUBD., PHASE II	
67	SADLER JOHN TOD	0142099134670044	LOT 43 LIGHTHOUSE BLUFFS SUBD., PHASE II	
68	ANDERSON CHARLES L & NANCY N S&T	0142099134670043	LOT 42 LIGHTHOUSE BLUFFS SUBD., PHASE II	
69	STAYANCHO JENNA M	0142099134670042	LOT 41 LIGHTHOUSE BLUFFS SUBD., PHASE II	
70	STAYANCHO KALI L	0142099134670041	LOT 40 LIGHTHOUSE BLUFFS SUBD., PHASE II	
71	DALENBERG KAREN R	0142099134670040	LOT 39 LIGHTHOUSE BLUFFS SUBD., PHASE II	
72	FERGUSON CARLA L	0142099134670039	LOT 38 LIGHTHOUSE BLUFFS SUBD., PHASE II	
73	ARNTZ CHARLES L & CAROL ANN S&T	0142099134670038	LOT 37 LIGHTHOUSE BLUFFS SUBD., PHASE II	
75	MIANO JOAN E TRUSTEE	0142099134670016	LOT 16 LIGHTHOUSE BLUFFS AMENDED 3/8/99	
76	PHILLIPS JEFFREY M & CAROL M S&T	0142099134670015	LOT 15 LIGHTHOUSE BLUFFS AMENDED 3/8/99	
78	BURGIN DAVID L & SHARON E BURGIN S&T	0142099134670014	LOT 14 LIGHTHOUSE BLUFFS AMENDED 3/8/99	
79	AMONETTE WILLIAM A	0142099134670013	LOT 13 LIGHTHOUSE BLUFFS AMENDED 3/8/99	
80	RAHM EVANGELINA	0142099134670012	LOT 12 LIGHTHOUSE BLUFFS AMENDED 3/8/99	
81	WENGER NORMAN C & MYRNA K S&T	0142099134670011	LOT 11 LIGHTHOUSE BLUFFS AMENDED 3/8/99	
82	DEAN R & PATRICIA A DVORAK S&T	0142099134670010	LOT 10 LIGHTHOUSE BLUFFS AMENDED 3/8/99	
83	HILL ARTHUR B & JUDITH A J&S	0142099134670009	LOT 9 LIGHTHOUSE BLUFFS AMENDED 3/8/99	
84	WIEDENHOFT DALE A & SUZANNE L	0142099134670008	LOT 8 LIGHTHOUSE BLUFFS AMENDED 3/8/99	
85	PIERCE JANENE CLAIRE TRUSTEE	0142099134670007	LOT 7 LIGHTHOUSE BLUFFS AMENDED 3/8/99	
86	GORMAN TIMOTHY W	0142099134670006	LOT 6 LIGHTHOUSE BLUFFS AMENDED 3/8/99	
87	HAWK DONALD R	0142099134670005	LOT 5 LIGHTHOUSE BLUFFS AMENDED 3/8/99	
88	MILLER BRIAN H	0142099134670004	LOT 4 LIGHTHOUSE BLUFFS AMENDED 3/8/99	
89	DANIEL KIMBERLY ANNE	0142099134670003	LOT 3 LIGHTHOUSE BLUFFS AMENDED 3/8/99	
90	BROWN VERNON & CHRISTINA M S&T	0142099134670002	LOT 2 LIGHTHOUSE BLUFFS AMENDED 3/8/99	
91	ETIENNE R & ANNE MARIE DETRACE S&T	0142099134670001	LOT 1 LIGHTHOUSE BLUFFS AMENDED 3/8/99	
92	BOARD OF EDUCATION DANBURY LOCAL SCHOOLS	0141095214637001	PART SECTION 1, LOT 4, DANBURY TWP.	
93	MEJ INC	0141095214637000	PART SECTION 1, LOT 4, DANBURY TWP.	
94	RENEE L CLAYCOMB	0142099134670052	LOT 50A LIGHTHOUSE BLUFFS SUBD., PHASE II REPLAT	
95	PROKOS DEMETRIOS	0141674330850009	LOT 8 ROCKPORT SUBD.	X
96	STATE OF OHIO DEPT OF NATURAL RESOURCES	0141914100003000	PART SECTION 1, LOT 2, DANBURY TWP.	X
97	STATE OF OHIO DEPT OF NATURAL RESOURCES	0141094014620000	PART SECTION 1, LOT 2, DANBURY TWP.	X
17				
74	LIGHTHOUSE BLUFFS CLUSTER HOMES ASSOCIATION	0142099134670037	OPEN SPACE PHASE I LIGHTHOUSE BLUFFS SUBD	
77				
38				
54	LIGHTHOUSE BLUFFS CLUSTER HOMES ASSOCIATION	0142099134670076	OPEN SPACE PHASE II LIGHTHOUSE BLUFFS SUBD	
61				
7	NORTHSHORE BLVD TR #257	0141909300001000		
8	NORTHSHORE BLVD TR #257			
9	NORTHSHORE BLVD TR #257			
10	NORTHSHORE BLVD TR #257			
11	NORTHSHORE BLVD TR #257			
15	LIGHTHOUSE OVAL TR #1261			
16	LIGHTHOUSE OVAL TR #1261			

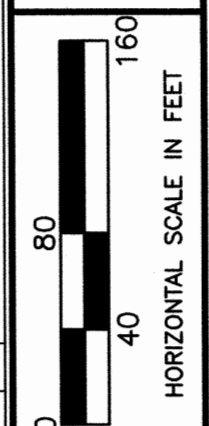

CALCULATED DBT CHECKED RPL

PROPERTY MAP
PERMANENT MAINTENANCE EASEMENT (ORC 6137.12)

ROCKPORT DRAINAGE
PETITION NO. 111

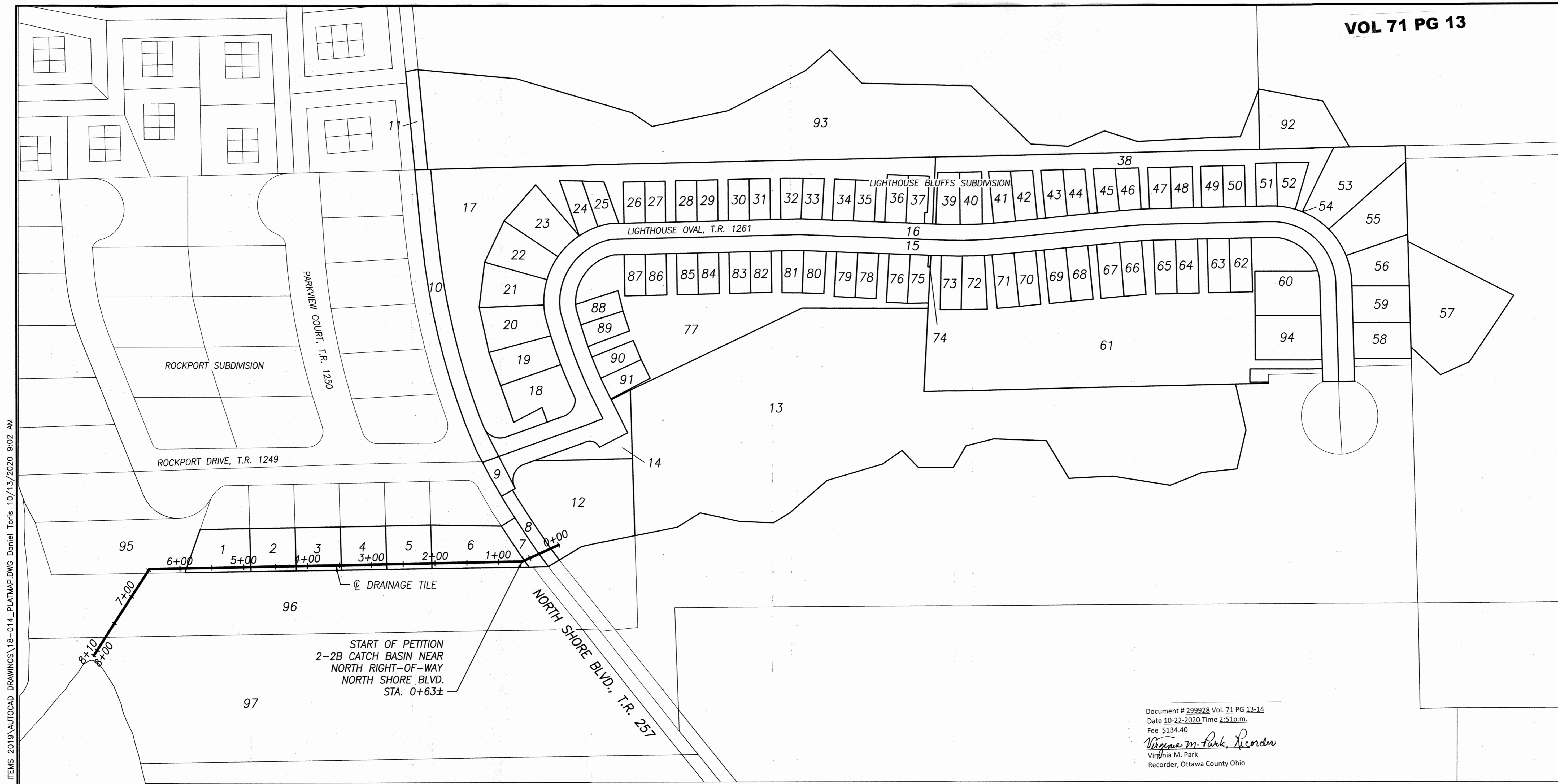

S:\DITCHES\ROCKPORT SUBDIVISION\ROCKPORT SUBDIVISION - PETITION ITEMS 2019\AUTOCAD DRAWINGS\18-014_PLATMAP.DWG Daniel Toris 10/13/2020 9:02 AM

Document # 299928 Vol. 71 PG 13-14
Date 10-22-2020 Time 2:51p.m.
Fee \$134.40
Virginia M. Park Recorder
Virginia M. Park
Recorder, Ottawa County Ohio

LEGEND:
— DRAINAGE BOUNDARY

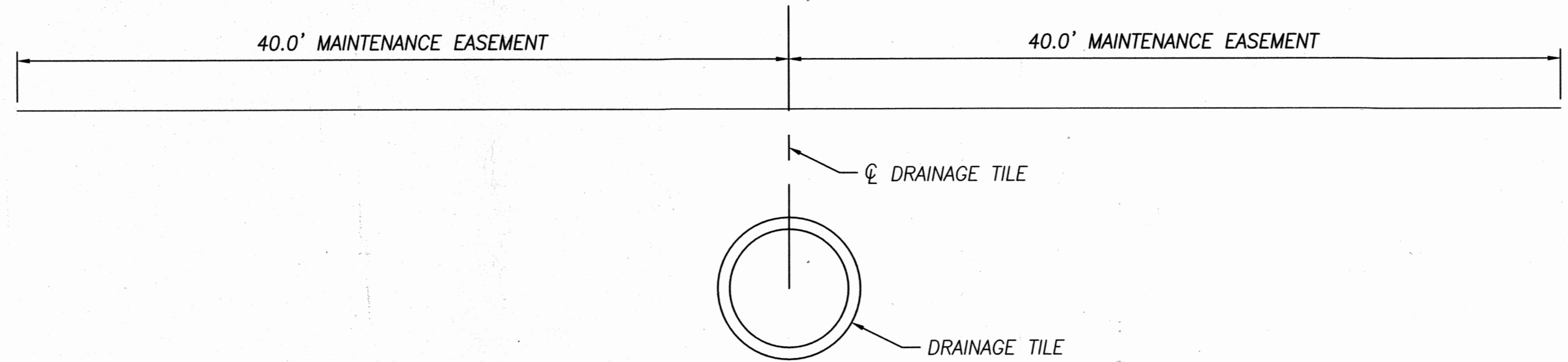

TYPICAL DRAINAGE IMPROVEMENT SECTION - ROCKPORT SUBDIVISION

I HEREBY APPROVE THESE PLANS.

Ronald P. Lajti, Jr.
RONALD P. LAJTI, JR., P.E., P.S.
OTTAWA COUNTY ENGINEER

10/15/2020
DATE



