

# REPAIRS TO VARIOUS WELDED STEEL BRIDGES OTTAWA COUNTY, OHIO 1981-82

## GENERAL NOTES:

- 1) EXISTING BRIDGE FLOOR SHALL BE REMOVED IN SUCH A MANNER SO AS NOT TO DAMAGE FLOOR JOISTS OR BEAMS OR ANY OTHER MEMBERS OF THE EXISTING STRUCTURE.
- 2) CARE SHALL BE EXERCISED SO THAT EXISTING BRIDGE FLOOR AND PAVEMENT DOES NOT FALL INTO STREAM. ANY MATERIAL WHICH ACCIDENTALLY FALLS INTO STREAM AREA SHALL BE REMOVED AT CONTRACTOR'S EXPENSE.
- 3) APPROACH PAVEMENT SHALL BE REMOVED APPROXIMATELY 25 FEET ON EITHER END OF STRUCTURE TO A DEPTH OF ABOUT 2 INCHES.
- 4) ALL REMOVED MATERIAL (ITEMS 1, 2 & 3 ABOVE) SHALL BE DISPOSED OF IN A PROPER MANNER SUCH AS TRUCKING TO AN APPROVED LANDFILL.
- 5) UNIT COST FOR REMOVAL OF EXISTING BRIDGE FLOOR TO INCLUDE GRINDING OR SUITABLY REMOVING OLD WELD BEADS, IF REQUIRED.
- 6) ALL FLOOR JOISTS AND OTHER STEEL BRIDGE MEMBERS REMOVED (WITH THE EXCEPTION OF THE FLOORING) SHALL BE THE PROPERTY OF OTTAWA COUNTY, AND SHALL BE PLACED ON COUNTY TRUCKS FOR DISPOSITION BY OTTAWA COUNTY.
- 7) ITEM 407 TACK COAT TO BE APPLIED AT THE RATE OF 0.15 GAL. PER SQUARE YARD.
- 8) ITEM 407 COVER AGGREGATE TO BE APPLIED AT THE RATE OF 10 LBS. PER SQUARE YARD.
- 9) ALL CORRUGATIONS IN STEEL BRIDGE FLOOR SHALL BE COMPLETELY FILLED WITH COMPACTED ITEM 404 ASPHALT CONCRETE BEFORE LAYING FINISH COURSE. FINAL GRADE SHALL CONFORM TO THE TYPICAL SECTION.
- 10) TOTAL AMOUNT OF STRUCTURAL STEEL (WF SHAPES, ANGLES, ETC.) TO BE USED ON ANY GIVEN STRUCTURE TO BE DETERMINED BY THE ENGINEER AFTER REMOVAL OF EXISTING BRIDGE FLOOR. UNIT PRICE BID SHALL GOVERN FOR ALL STEEL OF SIMILAR GRADE, REGARDLESS OF ROLLED SHAPE.
- 11) BRIDGE FLOOR PLATES OVER 12 FOOT IN LENGTH MAY BE SPARKED BY WELDING TWO OR MORE UNITS END TO END. ALL SPARGES SHALL CONSIST OF CONTINUOUS BUTT WELDS ON BOTH SIDES OF THE PLATE, EXCEPT THAT WHEN SPARGES OCCUR OVER FLOOR JOISTS OR BEAMS, THAT PORTION WHICH WOULD ACTUALLY BEAR ON THE JOISTS OR BEAMS SHALL BE OMITTED OR GRIND FLUSH. DAMS OF 10 GA. STEEL SHALL BE WELDED TO THE ENDS OF PLATES TO RETAIN SURFACING MATERIAL AND TO PROVIDE A DRIP EDGE FOR SURFACE WATER. SKEWED PLATES MAY BE SHOP FLAME CUT AS REQUIRED AND MARKED FOR ERECTION OR FIELD FLAME CUT. CONTRACTOR TO VERIFY SKEW ANGLE BEFORE CUTTING. IN THE CASE OF FIELD CUTTING, THE CUT EDGE ON GALVANIZED FLOORING SHALL BE TREATED WITH A COLD APPLIED GALVANIZED COMPOUND. ALL OF THE ABOVE SHALL BE INCLUDED IN THE UNIT PRICE BID FOR "5" GAUGE 2"x6" CORRUGATED STEEL BRIDGE FLOOR.
- 12) GALVANIZED PLATES SHALL BE HOT-DIP GALVANIZED (ASTM A-123).
- 13) FIELD PAINTING SHALL INCLUDE, BUT IS NOT LIMITED TO, THE SANDBLASTING AND CLEANING OF THE FLANGE AND WEB OF THE FLOOR JOISTS AND/OR BEAMS AS DIRECTED BY THE ENGINEER. ALL AREAS BLASTED AND CLEANED SHALL BE FIELD PRIMED WITH AN APPROVED RED LEAD PRIMER (108.06) AND BE GIVEN TWO (2) COATS OF APPROVED BLACK PAINT (108.11). PAYMENT WILL BE FOR ACTUAL LENGTH OF MEMBERS WHICH ARE SO TREATED.
- 14) ALL CONCRETE TO BE CLASS C (6 1/2 SAC MIX) USING NO. 8 STONE (WASHED) OR NO. 57 STONE (WASHED) AS COARSE AGGREGATE AND A WATER REDUCING ADDITIVE TO CONTROL SHRINKAGE. FINAL MIX DESIGN TO BE APPROVED BY THE ENGINEER. SUPPLIER TO BE ODOT APPROVED.
- 15) BONDING AGENT BETWEEN NEW CONCRETE AND OLD TO BE SIKADUR HI - MOD OR APPROVED EQUAL.
- 16) CONCRETE WORK SHALL INCLUDE, BUT IS NOT LIMITED TO, THE REPAIR AND/OR REPLACEMENT OF THE SEATS ON BRIDGE NO. SAL-41-0.70 AND BRIDGE NO. HAR-6-0.72, AND NO. BEN. 208-4.70. SPALLED OR DETEIORATED CONCRETE SHALL BE REMOVED BY AN APPROVED METHOD DOWN TO SOUND CONCRETE AS DETERMINED BY THE ENGINEER. THE NEW WORK SHALL BE PROPERLY FORMED, AND CHAMFERED WHERE APPROPRIATE, AND AN APPROVED BONDING AGENT (SEE NOTE 15) APPLIED BEFORE THE NEW CONCRETE IS PLACED. CURING PROCEDURES AS PER ITEM 511. COST OF THE ABOVE TO BE INCLUDED IN UNIT PRICE BID FOR CLASS C CONCRETE.

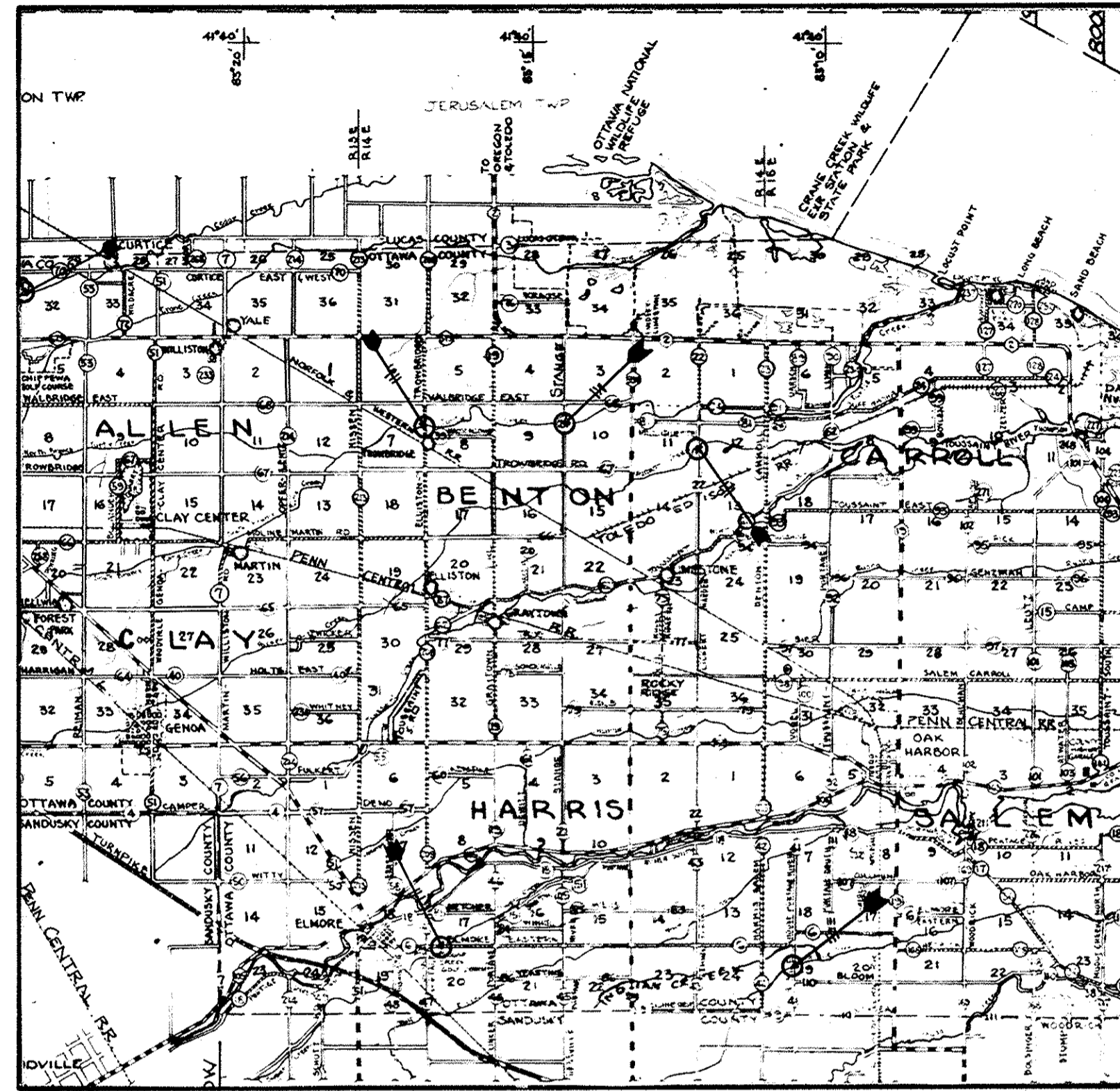

LOCATION PLAN

## SPECIFICATIONS:

ALL WORK SHALL CONFORM TO THE STATE OF OHIO, DEPARTMENT OF TRANSPORTATION, CONSTRUCTION & MATERIAL SPECIFICATIONS DATED JANUARY 1, 1981, AND ANY SUPPLEMENTS THERE TO IN EFFECT 14 CALENDAR DAYS PRIOR TO THE RECEIVING OF BIDS, UNLESS OTHERWISE NOTED OR EXCEPTED.

## GENERAL NOTES CONT'D

- 17) ALL NECESSARY CRIBBING, PILING, COPPER DAMS, JACKS, ETC., REQUIRED TO PROPERLY SUPPORT STRUCTURES HAVING CONCRETE REPAIR TO ABUTMENTS SHALL BE FURNISHED BY CONTRACTOR. MATERIAL AND WORKMANSHIP TO CONFORM TO ITEM 508, FALSEWORK AND FORMS. CONTRACTOR TO OBTAIN APPROVAL OF ENGINEER BEFORE ERECTING ANY SUPPORTS OR FALSEWORK.
- 18) SIZE AND PLACEMENT OF REINFORCING STEEL TO BE DETERMINED IN FIELD, BY THE ENGINEER, AFTER REMOVAL OF DETEIORATED CONCRETE. PAYMENT TO BE FOR TOTAL NUMBER OF POUNDS USED ON UNIT PRICE BASIS.
- 19) UNIT PRICE BID FOR BEARING BOXES OR BEARING PLATES TO INCLUDE PROPER ANCHORAGE TO BRIDGE SEATS.
- 20) CONTRACTOR TO VERIFY ALL MEASUREMENTS AND SKEW ANGLES BEFORE CUTTING MATERIAL.

## INDEX TO SHEETS

- 1-----LOCATION PLAN, EXISTING BRIDGE DATA, SPECIFICATIONS & GENERAL NOTES.
- 2-----GENERAL PLANS, TYPICAL SECTIONS & DETAILS.
- 3-----CONCRETE REPAIR, GENERAL PLANS & SECTIONS.

## EXISTING BRIDGE DATA:

- 1) BRIDGE NO. BEN-21-4.80 ~ SPANSE ROAD, NO. 21 OVER TURTLE CREEK.  
SIZE OF FLOOR JOISTS: W12x30  
SKEW: 23°40' - RIGHT FORWARD
- 2) BRIDGE NO. SAL-41-0.70 ~ FOUR MILE HOUSE ROAD, NO. 41 OVER LITTLE PORTAGE.  
SIZE OF FLOOR JOISTS: W10x26  
SKEW: 21°50' - RIGHT FORWARD
- 3) BRIDGE NO. BEN-22-4.35 ~ LICKERT-HARDER ROAD, NO. 22 OVER PACKER CREEK.  
SIZE OF FLOOR JOISTS: W12x30  
SKEW: 18°20' - RIGHT FORWARD
- 4) BRIDGE NO. ALL-54-3.64 ~ BILLMAN ROAD, NO. 54 OVER CEDAR CREEK.  
SIZE OF FLOOR JOISTS: W12x30  
SKEW: 0°0'
- 5) BRIDGE NO. HAR-6-0.72 ~ ELMORE EAST ROAD, NO. 6 OVER SUGAR CREEK.  
SIZE OF FLOOR JOISTS: W12x30  
SKEW: LEFT FORWARD - 17°30'

## CONCRETE REPAIR DATA:

- 1) BRIDGE NO. BEN. 208-4.70. OVER TURTLE CREEK
- 2) BRIDGE NO. HAR. 6-0.72 OVER SUGAR CREEK.

WORK TO COMMENCE FIRST ON ABOVE TWO STRUCTURES AND BE SUBSTANTIALLY COMPLETED BEFORE STARTING WORK ON STEEL BRIDGE REPAIRS.

## NOTE:

BRIDGE NO. FIVE, WAS ADDED TO THE LIST IN THE SPRING OF 1982, UNDER SEPARATE CONTRACT.

SEAL

OTTAWA COUNTY ENGINEER'S OFFICE  
PORT CLINTON, OHIO

REPAIRS TO VARIOUS WELDED STEEL  
BRIDGES IN OTTAWA COUNTY, OHIO

DESIGNED BY: ROBERT C. STEINMILLER  
DRAWN BY: JEFF UNDERWOOD  
APPROVED BY: JOHN H. HARRIS  
OTTAWA COUNTY ENGINEER

REVISIONS:

SEAL

**TYPICAL SECTION**

BRIDGE No. BEN-21-4.80  
 BRIDGE No. BEN-22-4.35  
 BRIDGE No. SAL-41-0.70  
 BRIDGE No. ALL-54-3.64  
 SCALE: 1 1/2" = 1'-0"

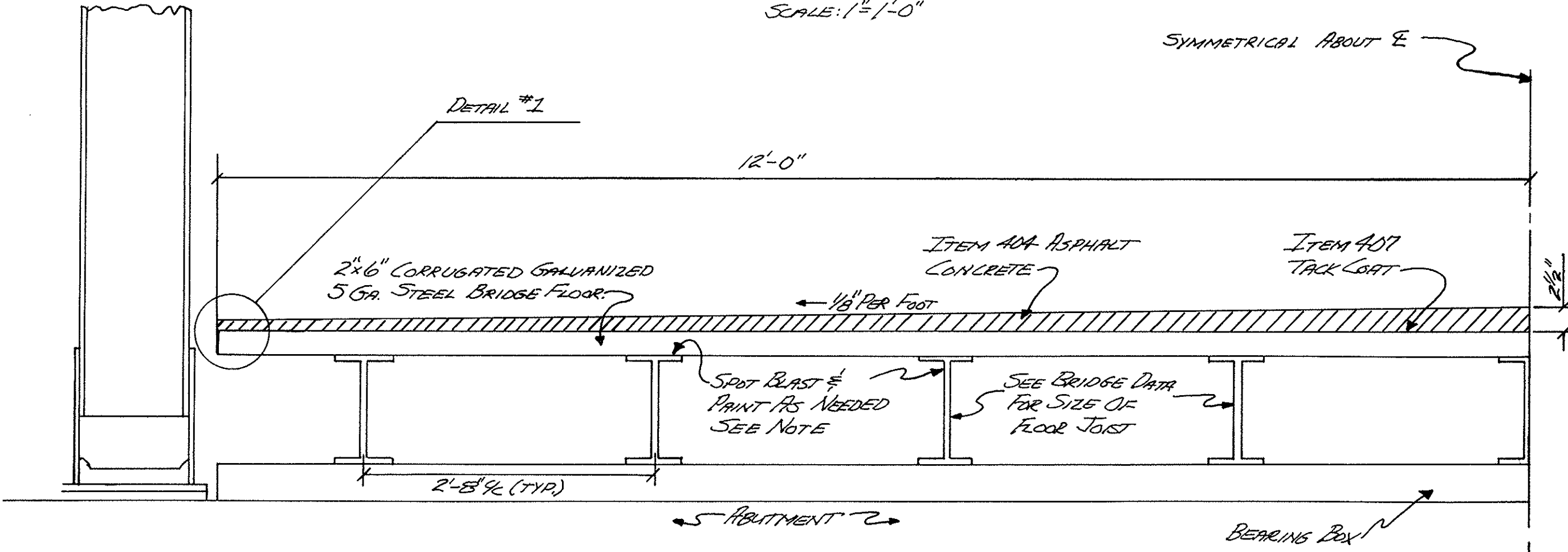

SYMMETRICAL ABOUT E

**SECTION A-A**

BRIDGE No. BEN-21-4.80  
 SCALE: 1 1/2" = 1'-0"

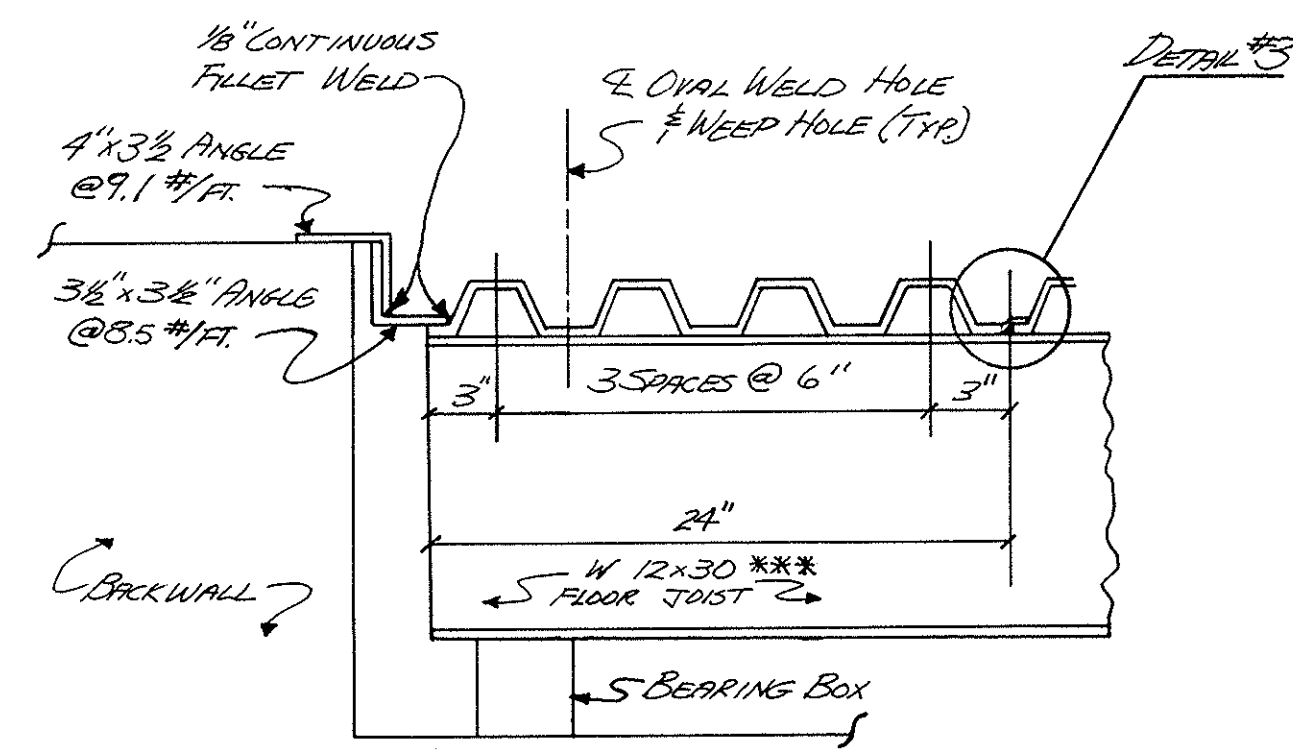

**GENERAL PLAN**

BRIDGE No. BEN-21-4.80  
 BRIDGE No. BEN-22-4.35  
 BRIDGE No. SAL-41-0.70  
 SCALE: 3/4" = 1'-0"

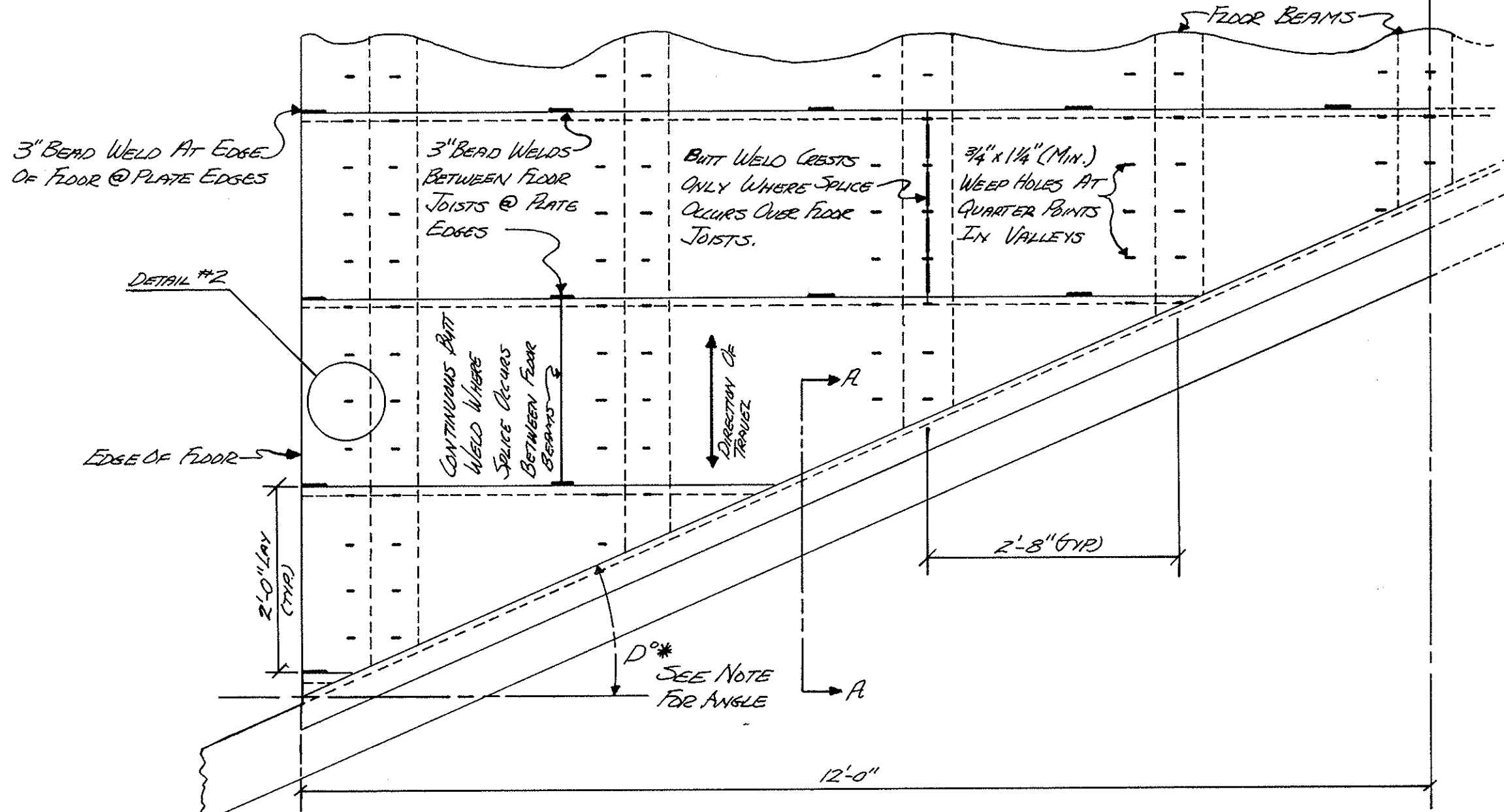

**SECTION A-A**

BRIDGE No. BEN-22-4.35  
 BRIDGE No. SAL-41-0.70  
 SCALE: 1 1/2" = 1'-0"

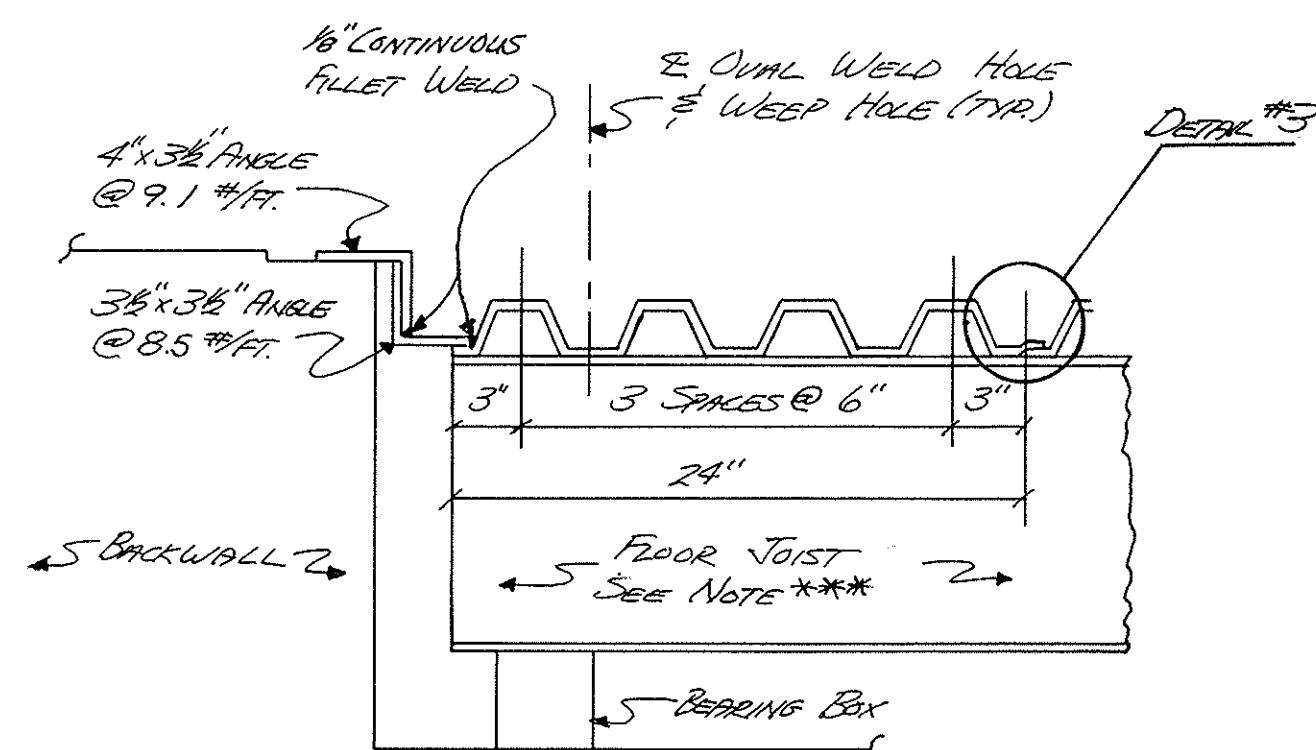

**BEARING BOX DETAIL**

TYPICAL  
 SCALE: 2" = 1'-0"

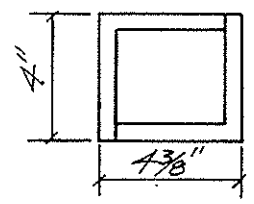

**DETAIL #1**

SCALE: 3" = 1'-0"

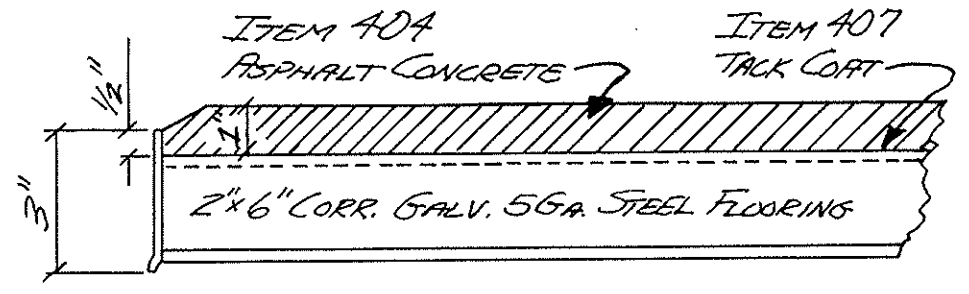

10 GA END DAMS FURNISHED SEPARATELY & FIELD WELDED TO FLOOR AFTER ERECTION

**DETAIL #2**

SCALE: FULL

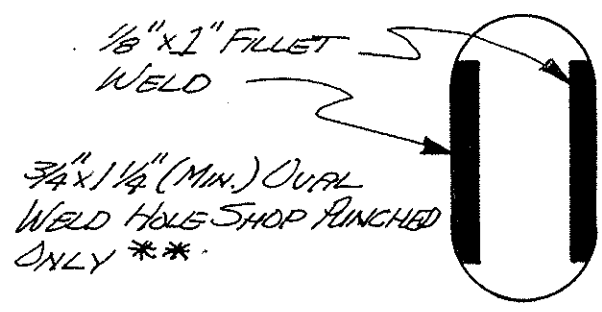

**DETAIL #3**

SCALE: 1/2 SCALE

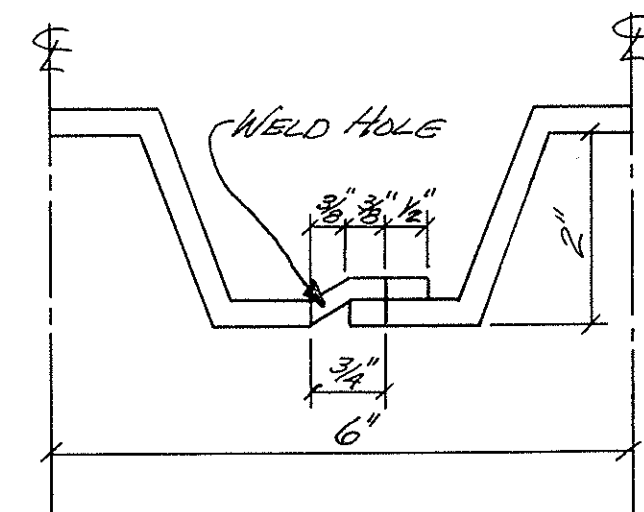

**NOTES:**

- \* SEE BRIDGE DATA FOR ANGLE.
- \*\* A 5/16" DIAMETER ROUND WELD HOLE WITH 3/16" x 3" FILLET WELD MAY BE USED INSTEAD OF OVAL WELD HOLE. HOLE TO BE SHOP PUNCHED ONLY.
- \*\*\* IF REQUIRED UNDER DIRECTION OF ENGINEER.

OTTAWA COUNTY ENGINEER'S OFFICE PART CLINTON, OHIO
REPAIRS TO VARIOUS WELDED STEEL BRIDGES IN OTTAWA COUNTY, OHIO
DESIGNED BY: ROBERT C. STEINMULLER
DRAWN BY: JEFF UNDERWOOD
APPROVED BY: [Signature] OTTAWA COUNTY ENGINEER
REVISIONS:

**CONCRETE REPAIR:**

BRIDGE No. HAR 6-0.72  
BRIDGE No. SAL 41-0.70  
SCALE: 1" = 1'-0"

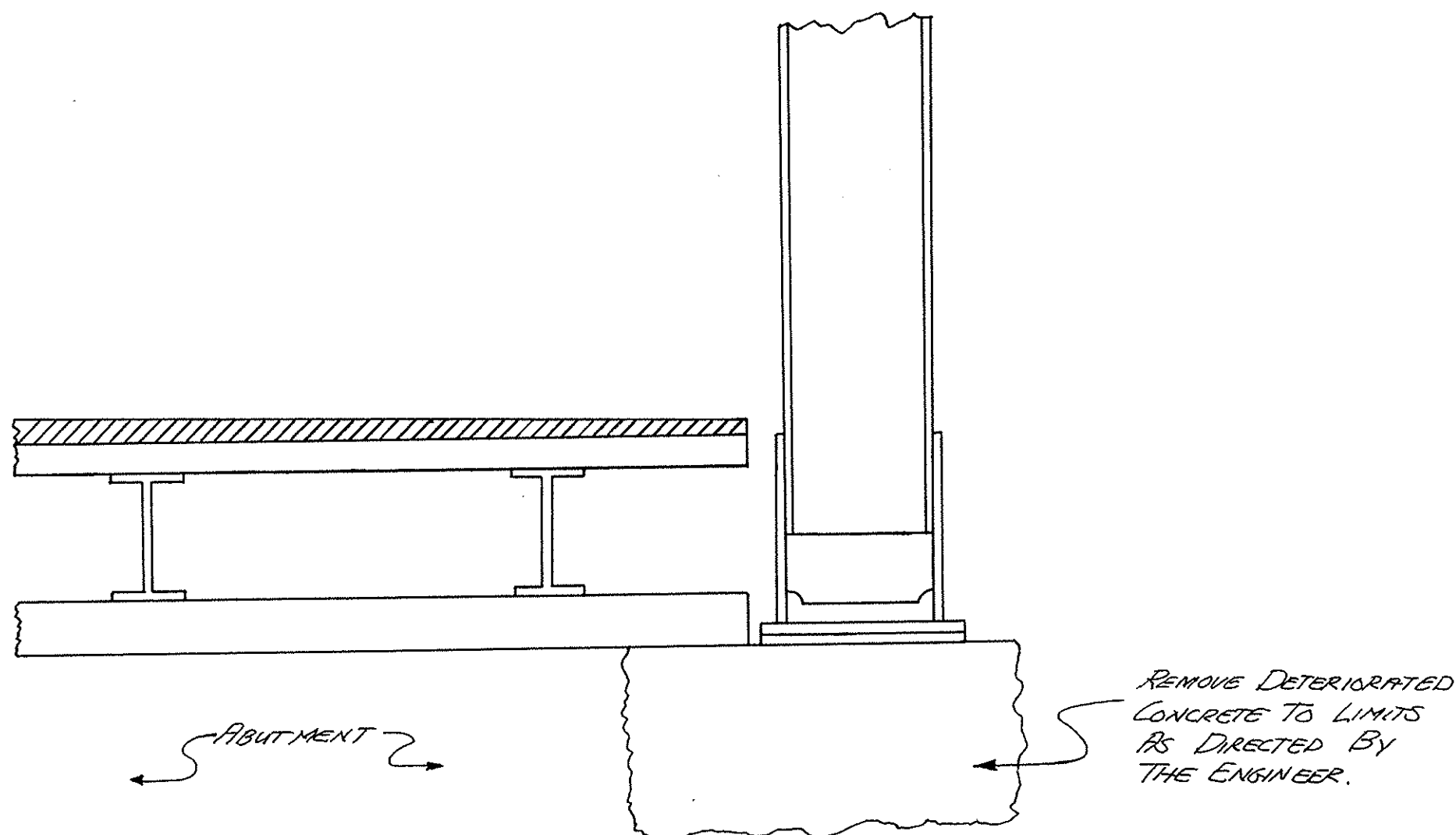

**GENERAL PLAN**  
BRIDGE No. ALL - 5A-3.64  
SCALE: 3/4" = 1'-0"

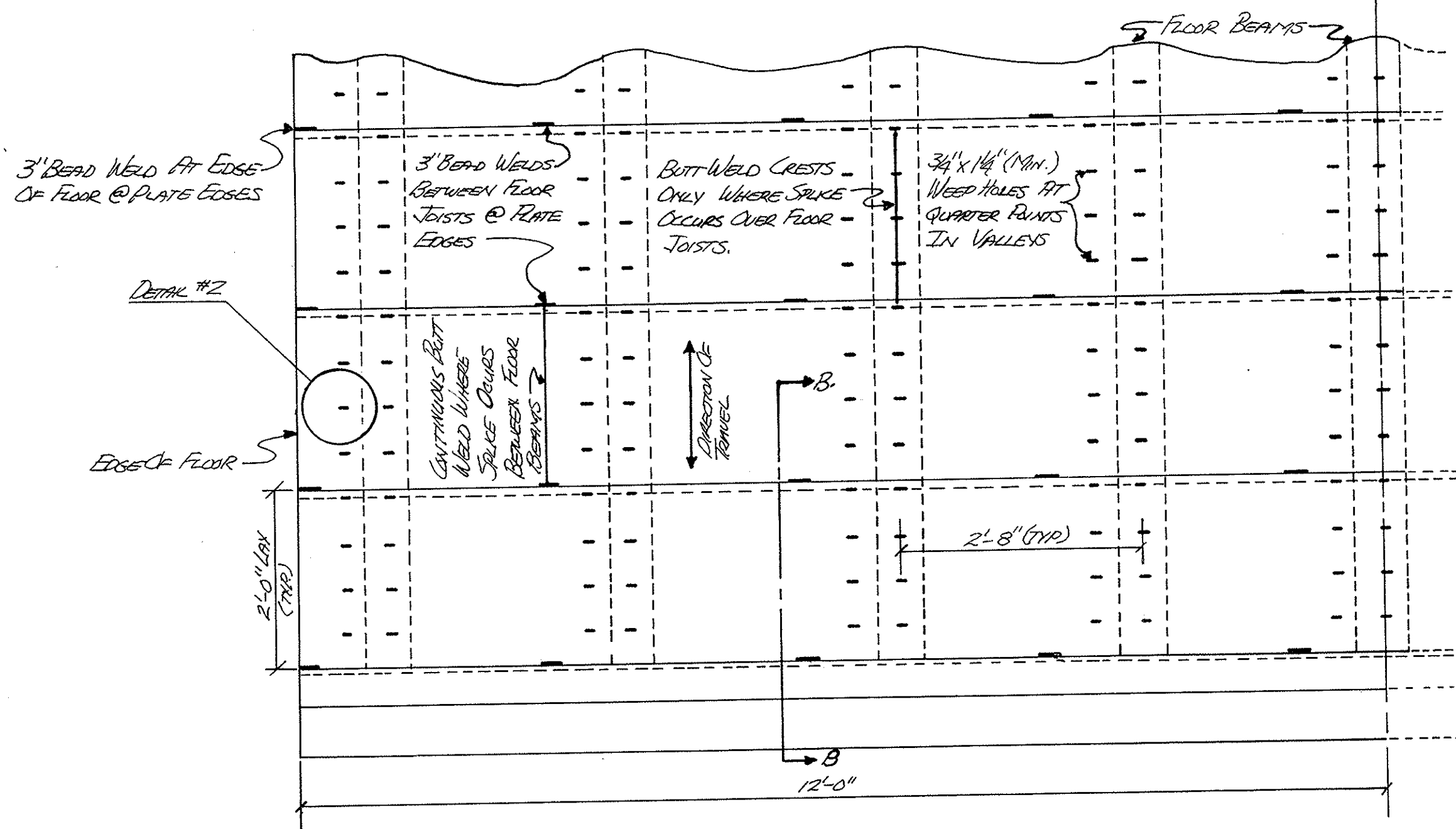

**CONCRETE REPAIR:**

BRIDGE No. BEN 208-4.70  
SCALE: 3/4" = 1'-0"

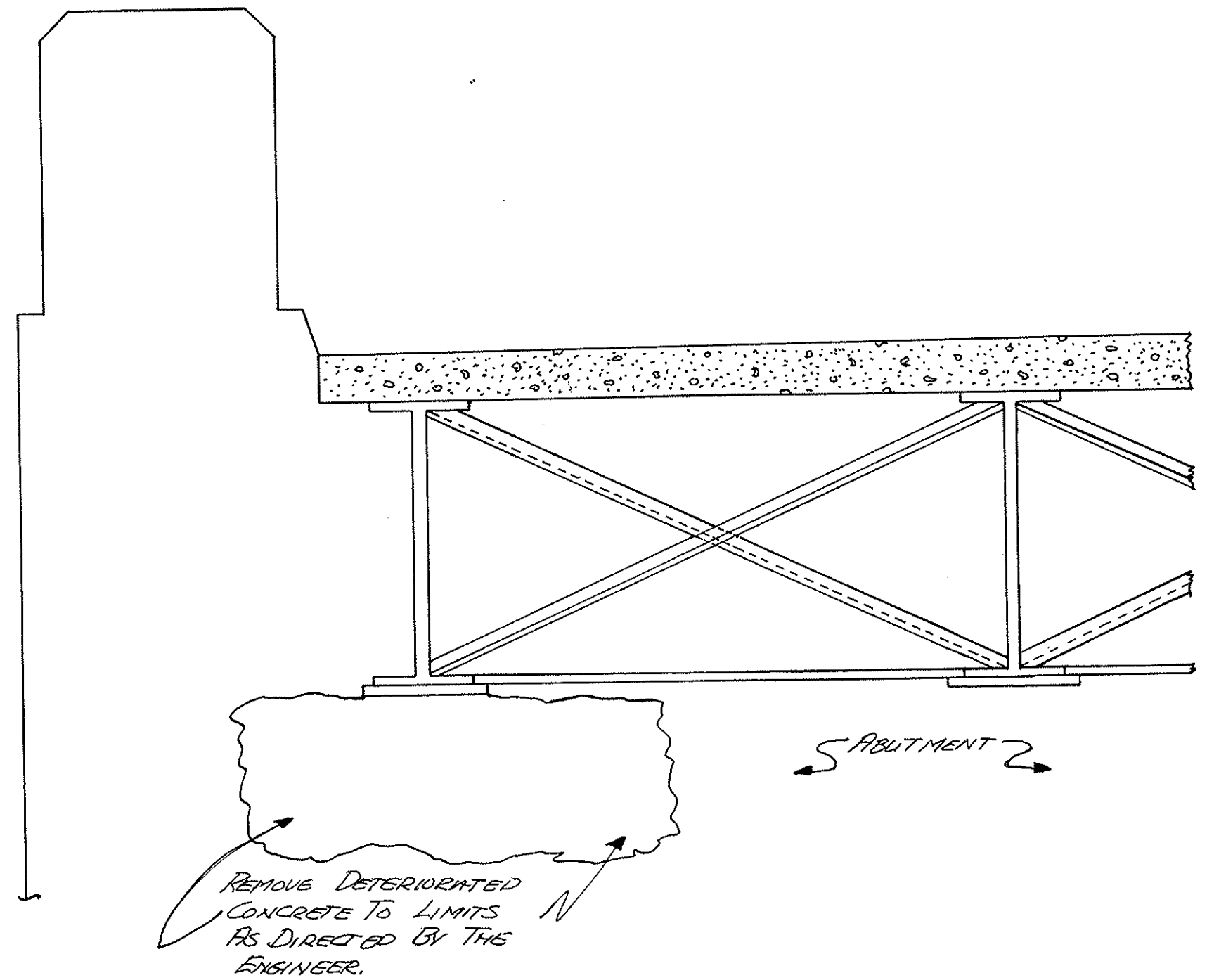

**SECTION B-B**  
BRIDGE No. ALL - 5A-3.64  
SCALE: 1/2" = 1'-0"

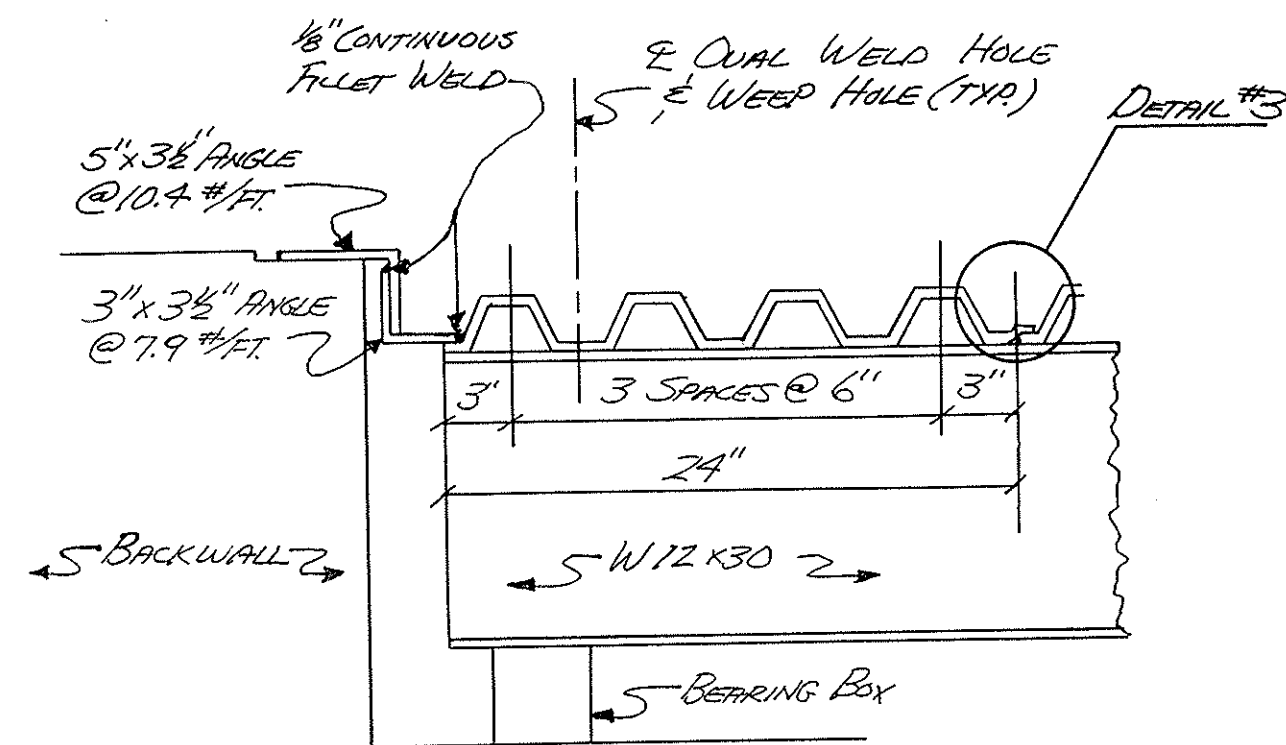

OTTAWA COUNTY ENGINEER'S OFFICE  
PART CLINTON, OHIO

REPAIRS TO VARIOUS WELDED STEEL  
BRIDGES IN OTTAWA COUNTY, OHIO

DESIGNED BY: ROBERT C. STEINMILLER

DRAWN BY: JEFF UNDERWOOD

APPROVED BY: *[Signature]*  
OTTAWA COUNTY ENGINEER

REVISIONS:

TYPICAL SECTION

BRIDGE No. HAR. 6-0.72  
SCALE: 3/4" = 1'-0"

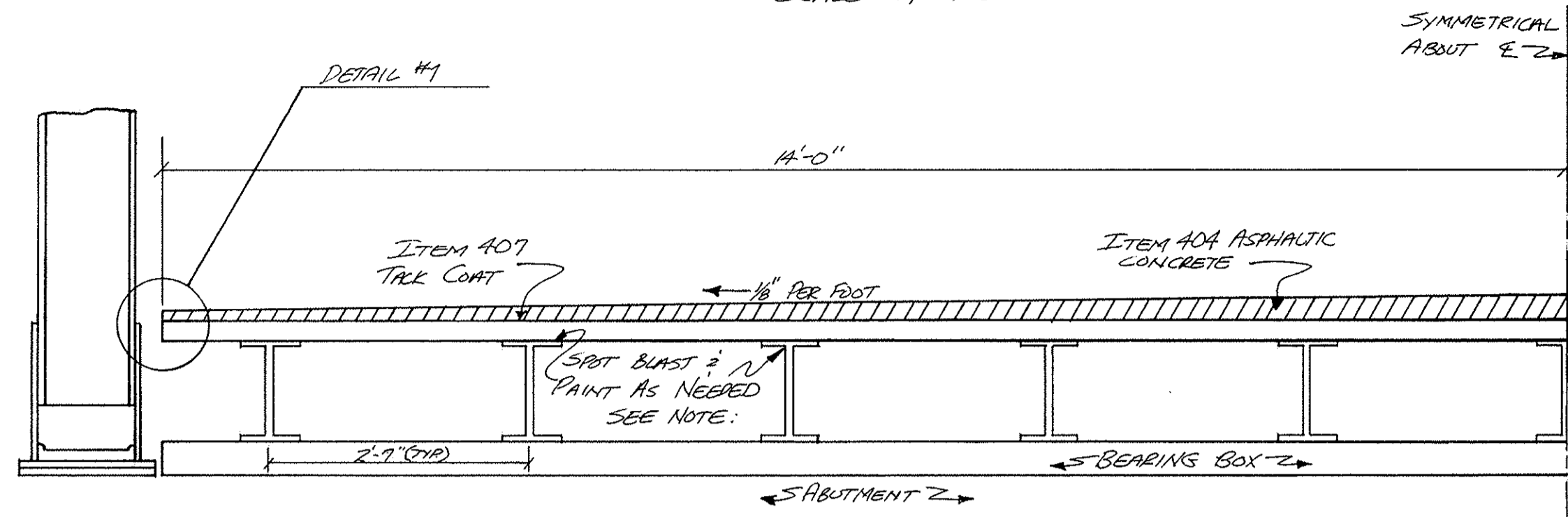

GENERAL PLAN

BRIDGE No. HAR. 6-0.72  
SCALE: 3/4" = 1'-0"

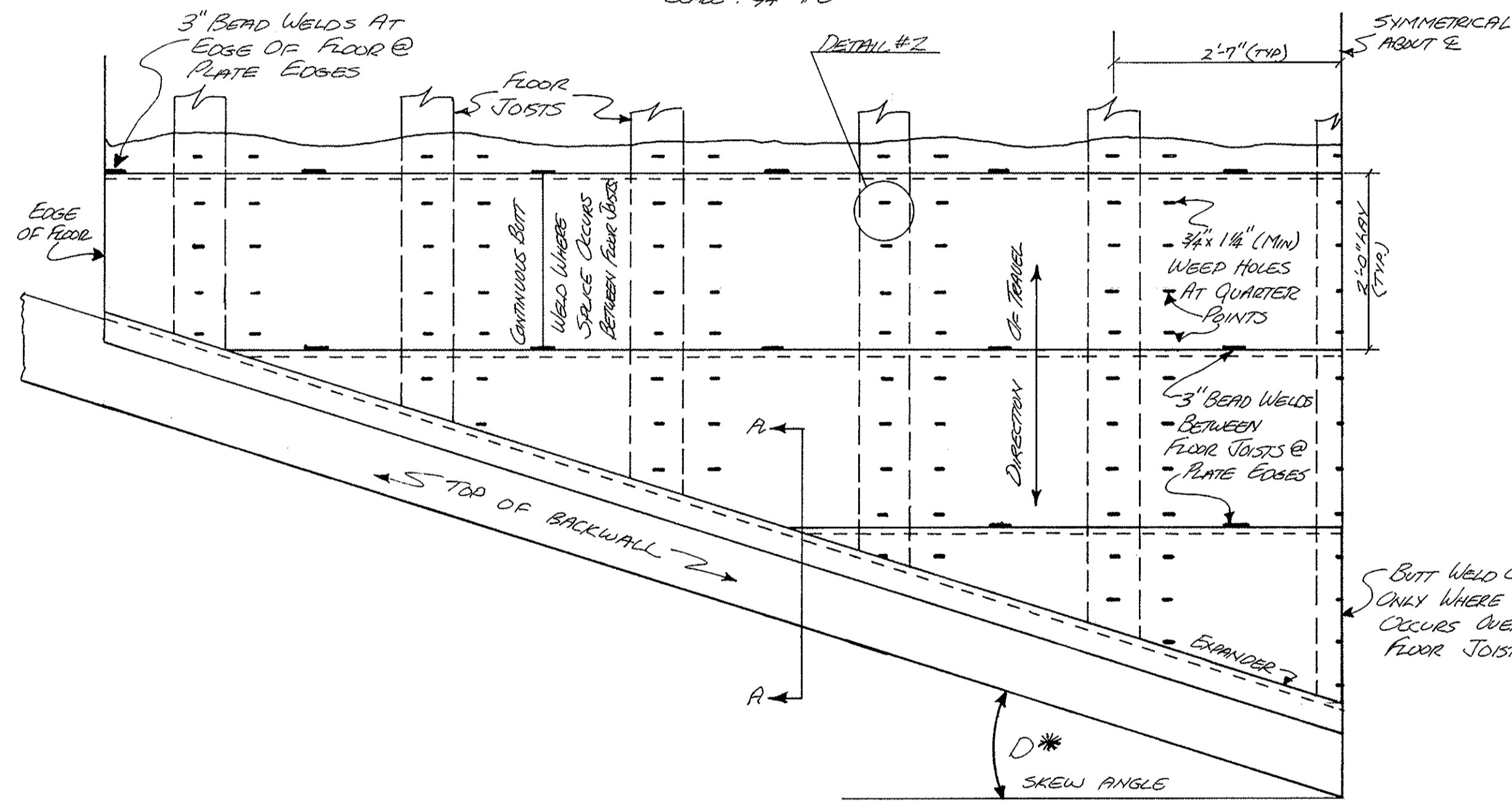

SECTION A-A

BRIDGE No. HAR. 6-0.72  
SCALE: 1 1/2" = 1'-0"

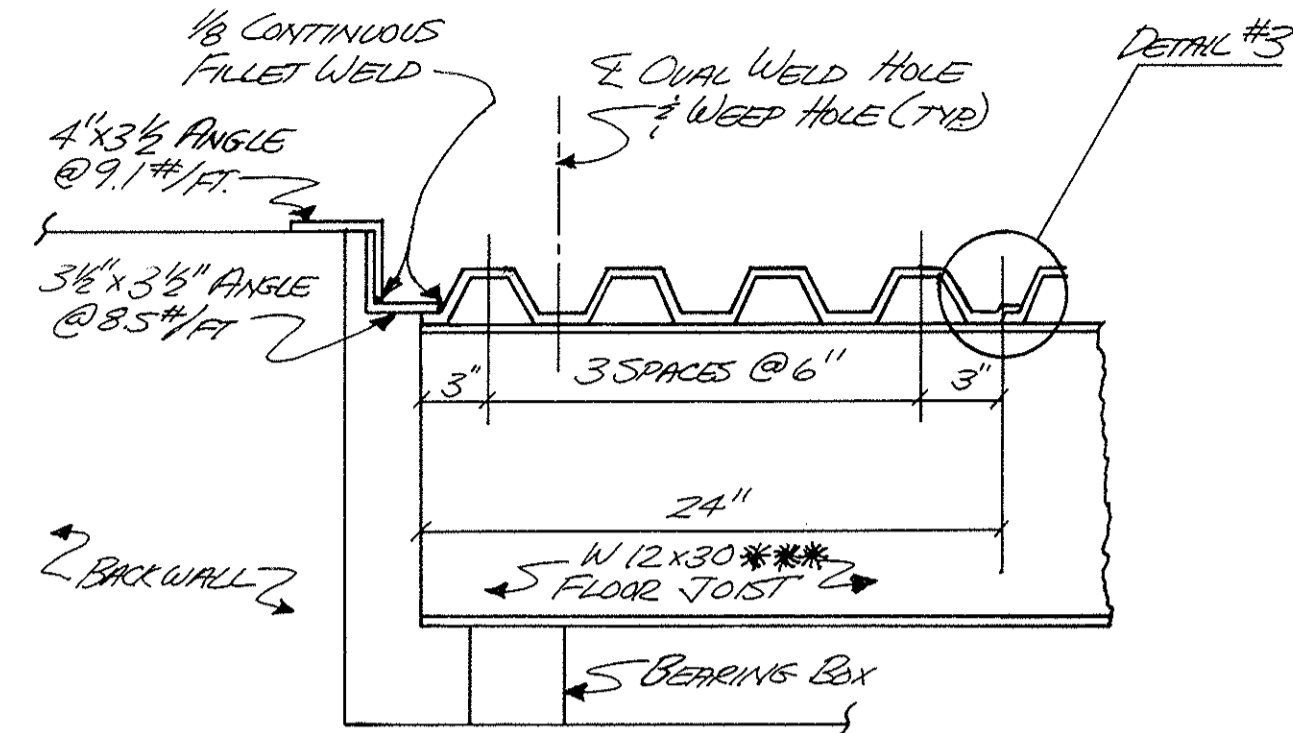

BEARING BOX DETAIL

TYPICAL  
SCALE: 2" = 1'-0"

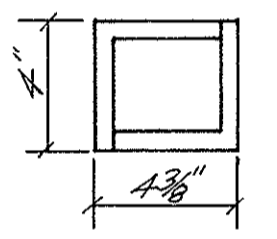

NOTES:

- \* SEE BRIDGE DATA FOR ANGLE.
- \*\* A 1 5/16" DIAMETER ROUND WELD HOLE WITH 3/16" x 3" FILLET WELD MAY BE USED INSTEAD OF OVAL WELD HOLE, HOLE TO BE SHOT PUNCHED ONLY.
- \*\*\* IF REQUIRED UNDER DIRECTION OF ENGINEER.

DETAIL #1

SCALE: 3" = 1'-0"

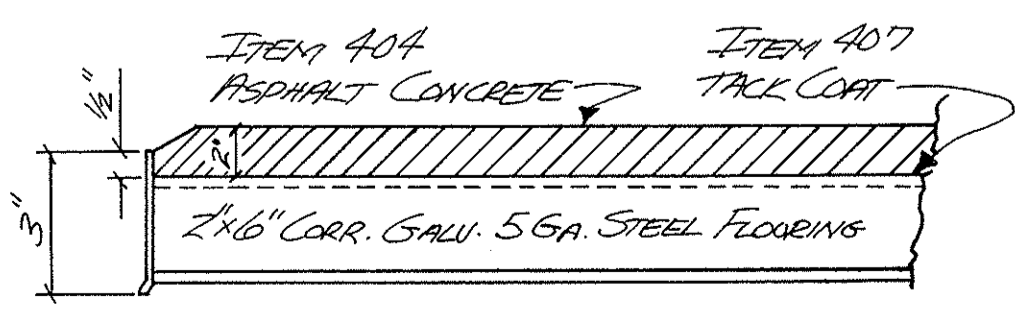

10 GA END DAMS FURNISHED SEPARATELY & FIELD WELDED TO FLOOR AFTER ERECTION

DETAIL #2

SCALE: FULL

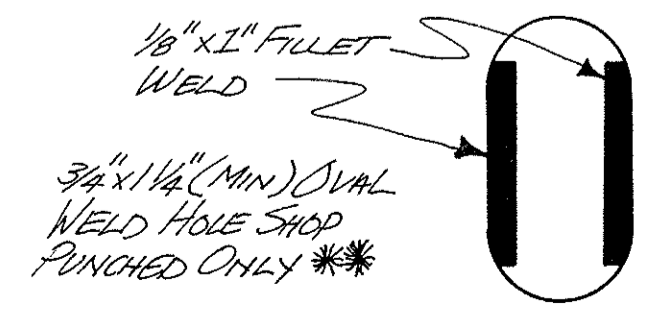

DETAIL #3

SCALE: 1/2" SCALE

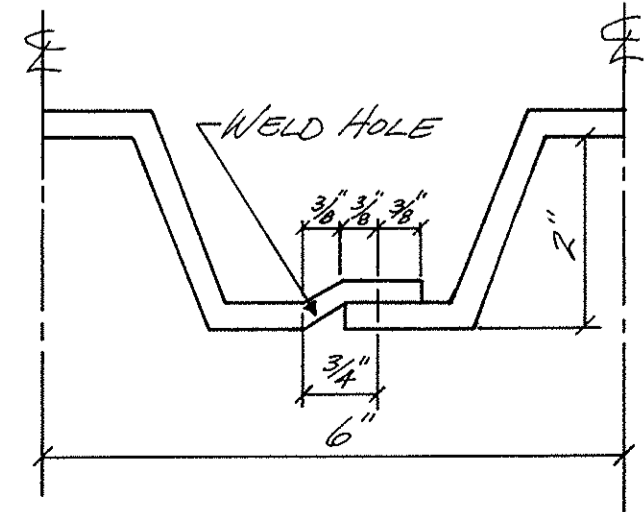

OTTAWA COUNTY ENGINEER'S OFFICE PORT CLINTON, OHIO
REPAIRS TO WELDED STEEL BRIDGES IN OTTAWA COUNTY, OHIO
DESIGNED BY: ROBERT C. STEINMILLER
DRAWN BY: JEFF UNDERWOOD
APPROVED BY: _____ OTTAWA COUNTY ENGINEER
REVISIONS: